

# TrinaTracker Spherical Bearing:

Unique  
Three-Dimensional  
Long-Lasting  
Patented  
Component

August 2021

*White Paper*

**TrinaTracker**



# Content

1	<b>Executive Summary</b>	3
2	<b>Introduction</b>	6
3	<b>Background and Evolution of the Spherical Bearing</b>	10
4	<b>Spherical Bearing Geometry Analysis and Advantages</b>	15
5	<b>Materials</b>	21
6	<b>Testing and Verification</b>	23
7	<b>Spherical Bearing: Minimum Failure Rate</b>	27
8	<b>Spherical Bearing Performance</b>	29
9	<b>Conclusions</b>	32
10	<b>Competitive Advantages of TrinaTracker</b>	34
11	<b>State-of-the-Art Engineering Solutions</b>	37
12.	<b>+6 GW of Solar Installations</b>	39

## Shu YunHua | White paper validation

Alfonso Caballero | Global Research and Development

Laura García | Global Product

Wen Jin Cai | Global Product

Marisa González | Global MarCom

Andrew Gilhooly | APAC Business Solutions



Executive  
Summary

# 1

# Executive Summary

## Alignment

The correct position of the components of the tracker to be able to track the sun correctly

## Bends

Deformations and deflections caused in the poles during their installation

## BOS cost

Cost of Balance of System will include the cost of the hardware (and software, if applicable), labour, permitting Interconnection and Inspection (PII) fees, and any other fees that may apply. For large commercial solar systems, the cost of BOS may include the cost of land and building, etc. The cost of BOS can be about two thirds of the total cost.

## CPP

Cermak Peterka Petersen, Inc.

## DNV

Det Norske Veritas

## EPC

Engineering, Procurement and Construction

## FEM

Finite Element Method

## Galvanized

A process that protects against corrosion

## Internal ribs

Reinforcements on the inside of the plastic parts

## LCOE

Levelized Cost of Energy (LCOE), or Levelized Cost of Electricity, is a measure of the average net present cost of electricity generation for a generating plant over its lifetime

## Magnelis

An exceptional metallic coating that provides a breakthrough in corrosion protection

## MTBF

Mean Time Before Failures

## O&M

Operation and Maintenance

## Piles

Post rammed into the ground

## Plastic injection

A method for obtaining plastic parts by injecting plastic into a mould

## PV

Photovoltaic

## Radial loads

The loads on the bearing from the centre of the bearing in the direction of the radius

## R&D

Research and Development

## ROI

Return on Investment (ROI) is a performance measure used to evaluate the efficiency or profitability of an investment or compare the efficiency of several different investments

## RWDI

Rowan Williams Davies & Irwin Inc.

## Torque tube

The profile that rotates along with the **Spherical Bearings** allowing tracking of the sun

**TrinaTracker** strives to be at the forefront of innovation and technology and its patented **spherical bearing**, which is unique in the photovoltaic market, is a result of its endeavour to maintain its positioning as a technological pioneer in the solar industry.

**Bloomberg New Energy Finance** (BNEF) estimated that between now and 2050, 77% of investments in new power generation will be in renewables.

Specifically, utility-scale photovoltaic energy has become an attractive investment area since installation and interconnection times are short, and it involves low risk, since energy production can be easily predicted.

The reliability of solar power plants depends on how accurately the solar trackers can follow the course of the sun. The more precisely these solar systems operate, the more efficient and the more profitable the plants will, therefore, be.

The quality of solar trackers is the key to making PV projects reliable assets. Moreover, the **bankability** of projects is mostly evaluated by the quality of system components.

Therefore, bearings make an important contribution here since they are critical for the reliability and cost effectiveness of the solar power plant. These components must have high rigidity and high load-carrying capacities even when operating under extreme conditions.

**TrinaTracker's Research and Development Department** (R&D) is continuously developing improvements in the quality and design of all components in the trackers, thus increasing their reliability, and decreasing failure rates.

The company strives to be at the forefront of innovation and technology and its patented **spherical bearing**, which is unique in the photovoltaic market, is a result of its endeavour to maintain its positioning as a **technological pioneer** in the solar industry.

**TrinaTracker** offers long-lasting reliable products that achieve optimized production, and increase the life expectancy of the installation while reducing **BOS** and **LCOE** to provide maximum **ROI** to their customers.



# Introduction

**TrinaTracker works non-stop to better its design and offer trackers that include the most innovative components. Many of the components are unique in the market, like the patented "Spherical Bearing"**

Regarding solar trackers, the design optimization of any component can contribute to achieving a more accurate rotation movement to follow the sun and capture most of the existing radiation in a particular site.

When it comes to innovation and technology, **TrinaTracker**, is always.

The company works non-stop to better its design and offer trackers that include the most innovative components. Many of the components are **unique in the market**, like the patented "**Spherical Bearing**."

In general terms, a bearing is an element that allows the rotation of a torque tube on a fixed part or structure.

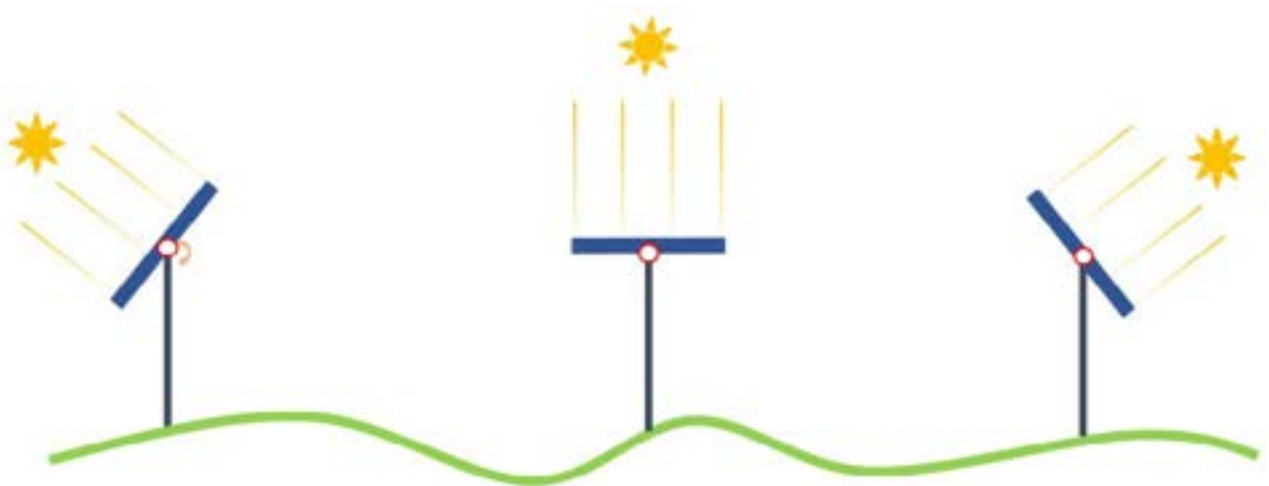


Image 1: Tracker rotation

The use of bearings in the photovoltaic sector arises from the need to make a semi-fixed structure that allows for tracking the sun's position to take advantage of solar energy throughout the sun's cycle.

The bearing assembly is one of the main parts of a tracker. Apart from being the component that allows the torque tube to rotate (and therefore the tracking of the sun), it is the element that **keeps the torque tube anchored to the piles**, and therefore it will have to withstand high vertical, horizontal, and axial loads.

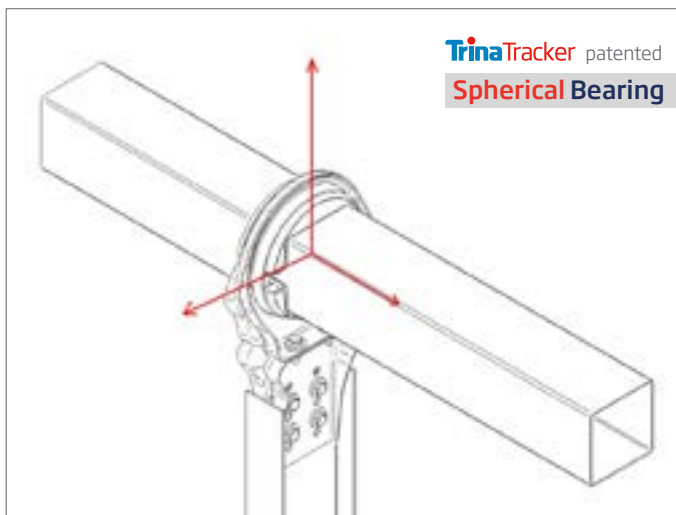


Image 2: Vertical, horizontal, and axial loads

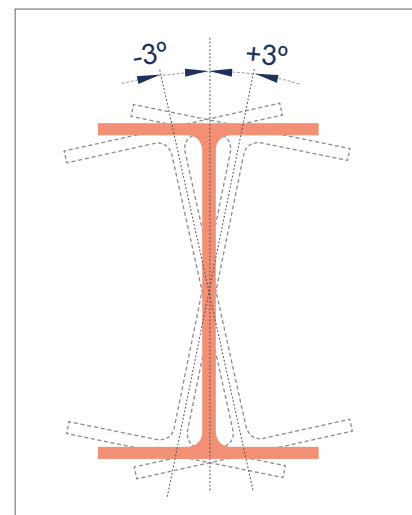


Image 3: Tolerance on post twist

Without bearings, a single-axis tracker would only be a fixed structure. A good bearing design will allow for optimal tracking, minimizing energy losses due to friction. It will also allow **reduction of assembly time** and the **reduction and absorption of the twisting** generated from the driving in of the posts.



A good bearing design will allow for **optimal tracking**, minimizing energy losses due to friction. It will also allow **reduction of assembly time** and the reduction and absorption of the twisting generated from the driving in of the posts.



Video 1: Spherical bearing rotation



Video 2: Spherical bearing rotation

# Background and Evolution of the Spherical Bearing

# 3

## Background and Evolution of the Spherical Bearing

**TrinaTracker R&D Department has gone a step further: the component, through its three-dimensional articulation, rather than two-dimensional axial movement, provided such significant added value, easing and lowering risk to the tracker installation that the company decided to patent the product.**

The first bearing design was cylindrical. In the first assembly of a test tracker, the problems of assembly and alignment became apparent.

Initially, all bearings were, and still are cylindrical; however, **TrinaTracker R&D Department** has gone a step further, and after analysing and testing the installation and operation of the trackers with bearings installed, the team discovered that there was still room for improvement.

When the R&D Department installed the cylindrical bearings in testing tracker samples, they identified specific issues related to the **assembly and alignment**, derived from the mechanical operation.

The use of cylindrical bearings meant adding an extra difficulty in the alignment of the trackers since they can overcome neither the bends of the poles nor the irregularities of the ground.

Alignment is a crucial process for **EPC companies** during the assembly process since the proper functioning of the tracker depends on a precise alignment.



**Image 4:** Spherical bearing installed in Habei, China, 400 MW

After the performance and testing of different bearings, **TrinaTracker** designed and implemented a spherical geometry for these elements. The component, through its **three-dimensional articulation**, rather than two-dimensional axial movement, provided such significant added value, easing and lowering risk to the tracker installation that the company decided to patent the product.



**Image 5:** Spherical bearing installed in Habei, China, 400 MW

Modality	Number	Name	Status	Application date	Due date	Next Payment	Classification	Country	Drawing
European Patent	<a href="#">EP2735817A3</a> <a href="#">EP2735817A2</a>	Swivel mount for solar tracker shafts	Granted	22/11/2013	30/11/2020	9 <sup>th</sup> annuity	F16C11/06; F24J2/52; F24J2/54; F16C23/04	DE IT ES	
European Patent	<a href="#">EP2735817B1</a> <a href="#">EP2735817B8</a>	Soporte giratorio de ejes de seguidores solares Swivel mount for solar tracker shafts	Granted	22/11/2013	30/11/2020	8 <sup>th</sup> annuity	F16C23/04; F24S20/70; F24S30/40;	DE IT ES	
Spanish Patent	<a href="#">ES2709659T3</a>	Soporte giratorio de ejes de seguidores solares	Granted	22/11/2013	30/11/2020	8 <sup>th</sup> annuity	F16C23/04; F24S20/70; F24S30/40;	ES	
Spanish Patent	<a href="#">ES2397777B1</a>	Soporte giratorio de ejes de seguidores solares	Granted	22/11/2012	30/11/2020	8 <sup>th</sup> annuity	F16C23/04; F24J2/52; H01L31/042;	ES	
US Patent	<a href="#">US9303684B2</a> <a href="#">US2014140755A1</a>	Swivel mount for solar tracker shafts	Granted	11/11/2013	05/10/2023	2 <sup>nd</sup> Four year period	F16C11/06; F16D3/00; F24J2/54; F16C23/04; F24J2/52;	USA	
Spanish Patent	<a href="#">ES2651916A1</a> <a href="#">ES2651916B1</a>	Soporte giratorio para eje de seguidor solar Rotating support for solar following axis and solar follower	Granted	29/07/2016	31/07/2021	6 <sup>th</sup> annuity	F16C19/00; F24S25/70; F24S30/425;	ES	

**Table 1:** Spherical bearing patents



This **spherical bearing** design helps the alignment of the tracker, as it aligns itself. As a result, it **eases and reduces time of installation** for EPC companies (including reduction in civil works and cut and fill costs and risks) and improves the trackers' unimpeded operation in service.



Image 6: **Spherical bearing** assembled in Vanguard 2P

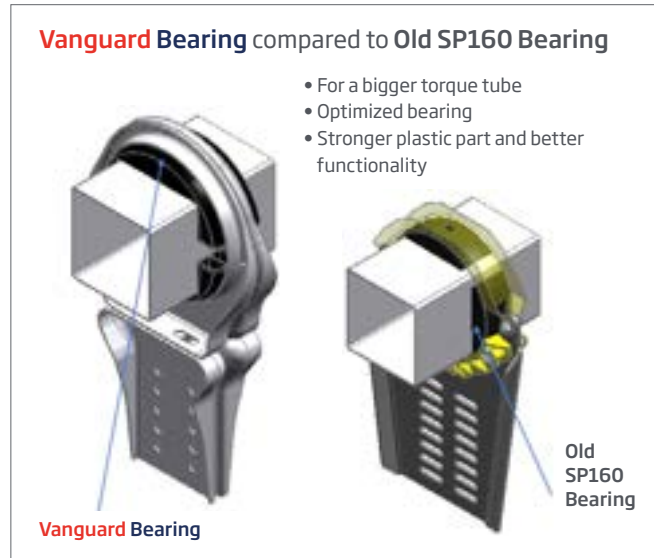


Image 7: Evolution of **spherical bearing**

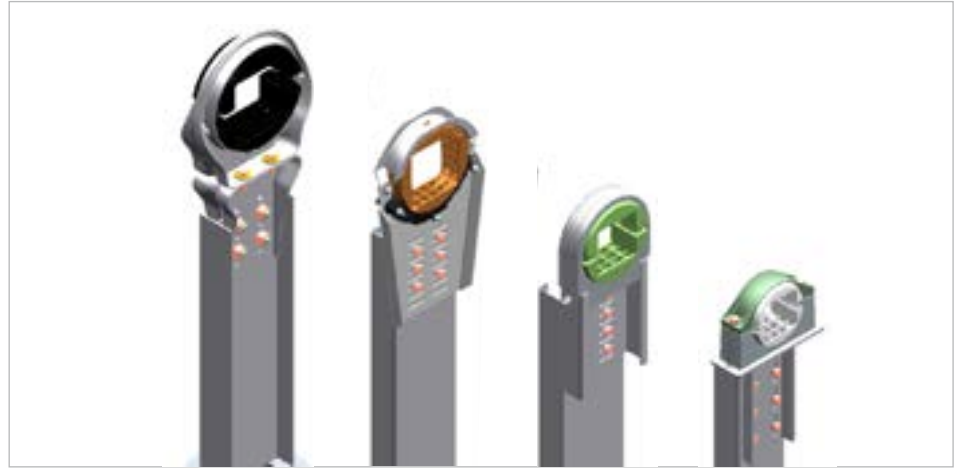
The new bearing design makes the joints more efficient; therefore, **maintenance is no required**.

The joint of the lower bearing support to the W post is designed with **circular holes** instead of slotted holes. This restricts movement associated with long term settlement and accordingly improves durability.

The component is made of UV stable and hard-wearing polyamide with fiberglass, which allows for the rotation axis to slide while **self-lubricating** when trackers move.

Since the adoption of this type of geometry, the **spherical bearing** became a critical element of the company's trackers. The bearing design has been in continuous **evolution and optimization**, adapting to the different characteristics of **TrinaTracker Agile 1P** and **Vanguard 2P** and innovating in materials, both in plastics and metallic housings.

The evolution of the bearing is going hand in hand with the development of the trackers, keeping up with the latest updates and optimization of the tracker industry in terms of **innovation leadership**.



**Image 8:** Different **spherical** bearing designs

Spherical bearing	Agile 1P	Vanguard 2P
Housing material	PA66+GF30	S420GD
Support material	S420GD (excellent thermal performance & UV resistant)	
Sphere	POM (Excellent at self-lubrication, Hydrolysis resistance, stability of size in different temperatures, UV resistant)	
Adaptability	Designed to be installed in different type of piles	
Assembly	Flexible assembly (Split design)	Rigid assembly (robust design)
Dimensions	Adapted for 100, 120 mm torque tube	Adapted for 170 mm torque tube
Designed for	Tilted stow position and high horizontal loads	Extremely high mechanical strength

**Table 2:** Differences between **Vanguard 2P** and **Agile 1P**'s **spherical** bearing



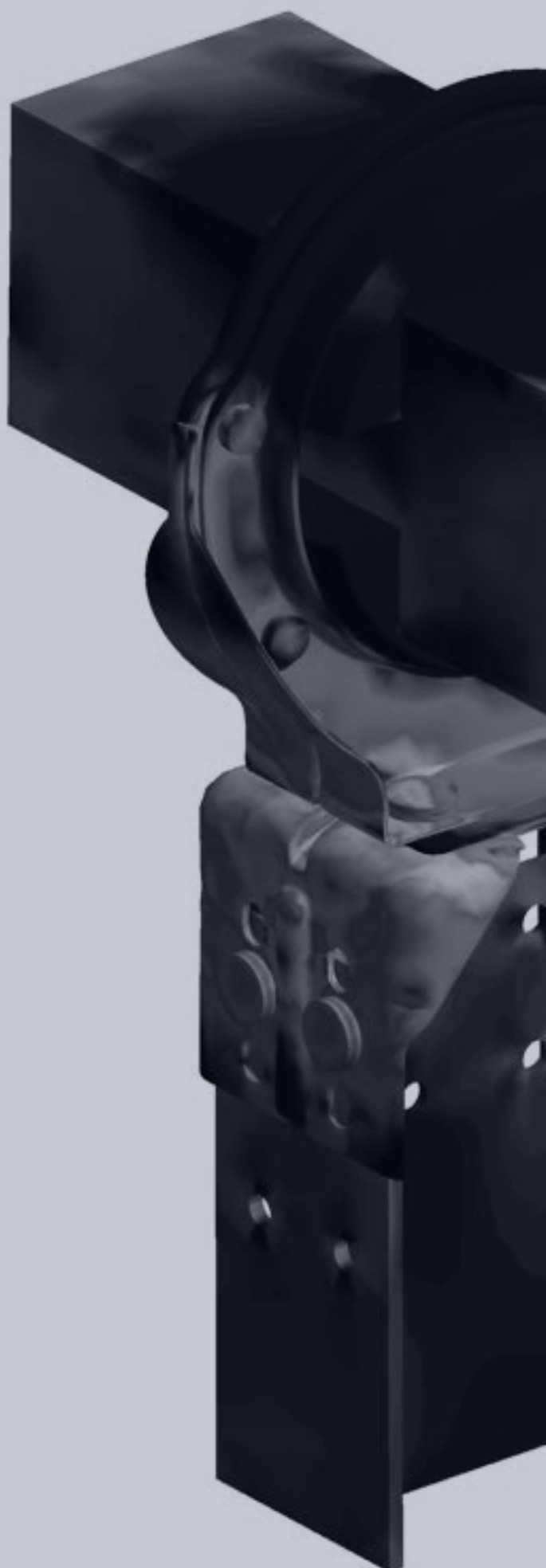
**Image 9:** **Agile 1P** **spherical** bearing

**Image 10:** **Vanguard 2P** **spherical** bearing



# 4

## Spherical Bearing Geometry Analysis and Advantages



# 4

## Spherical Bearing Geometry Analysis and Advantages

TrinaTracker has patented the **spherical bearing**, and therefore, it is unique to the **Vanguard 2P** and **Agile 1P** series. The rest of the trackers available in the market employ cylindrical bearings.



Image 11 y 12: Example of a commercial cylindrical bearing

The bearing structure is very simple at a first sight. It is comprised of two parts: the "housing," or fixed part, and the "Sphere" or moving part.



Image 13: Housing (fixed part)

Image 14: Sphere (moving part)

TrinaTracker patented **spherical bearings** can move around the three axes of rotation. This type of bearing has worked efficiently for **more than ten years** during the operation phase of trackers. The split feature of the bearing enables expedient installation of the torque tubes into the bearing assembly before the other bearing half and cap are assembled.

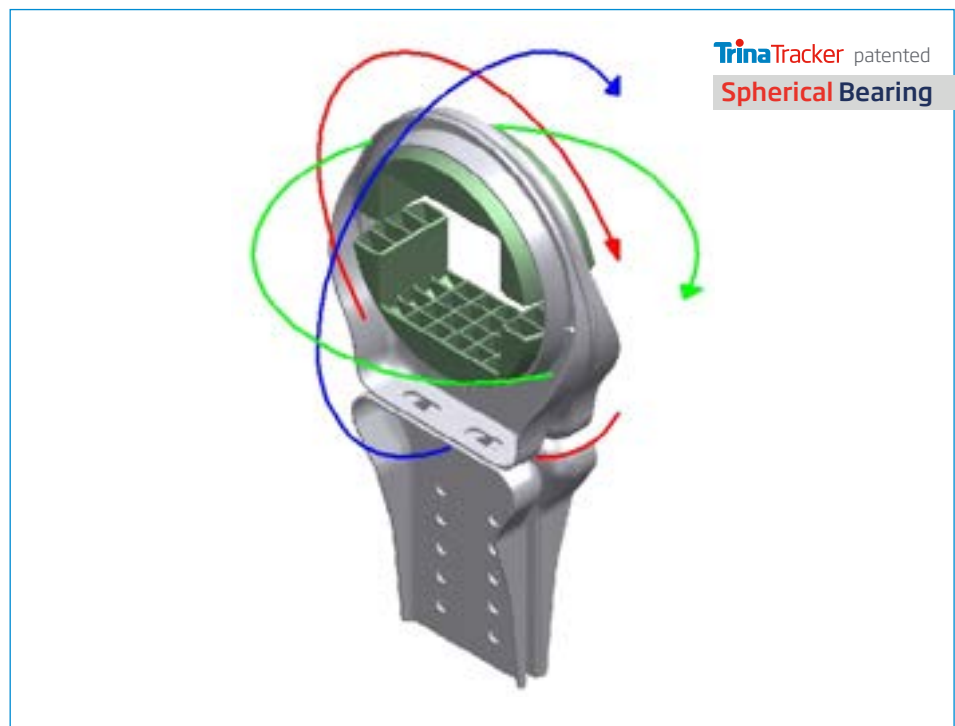
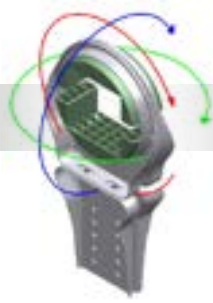


Image 15: Three-axis rotation



**TrinaTracker** patented

## Spherical Bearing

The advantages of **spherical** bearings over cylindrical bearings are the following:

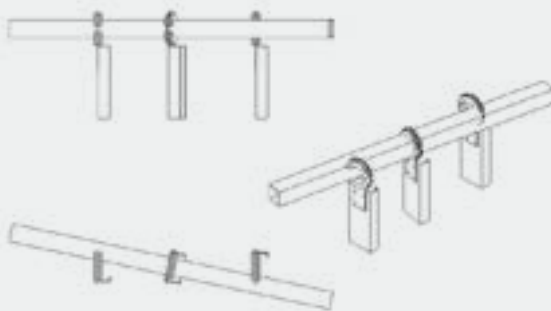
### 1 Absorption of the twist of the posts

The torsion in the "Z" axis (longitudinal axis of the post) keeps the sphere inside the **spherical bearing** housing (cavity) and therefore maintains its ability to **rotate within tolerance**.

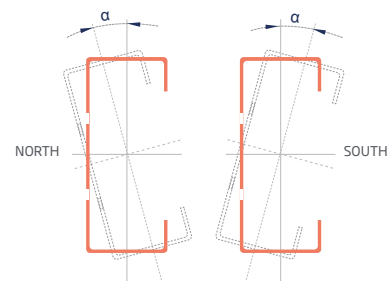
Installing cylindrical bearings would likely result in twisted posts. This effect is avoided by assembling **spherical bearings**.



**Image 16:** Cylindrical bearing structure



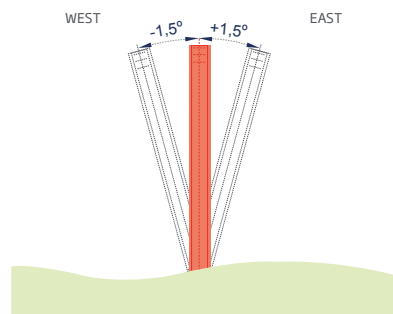
**Image 17:** Misalignment with cylindrical bearings on twisted post



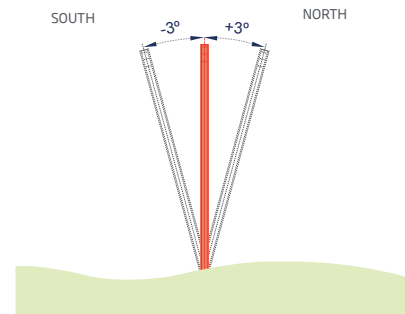
**Image 18:** Twist tolerance

## 2 Absorption of ground slope

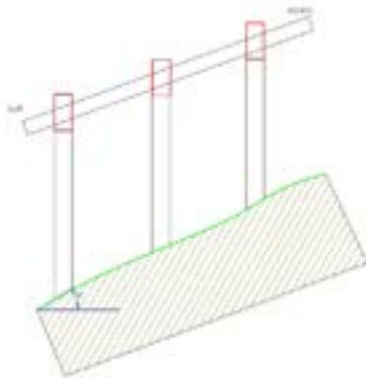
In **uneven terrains**, the bearing geometry can rotate by itself requiring without making extra adjustments or adding elements to the bearing.



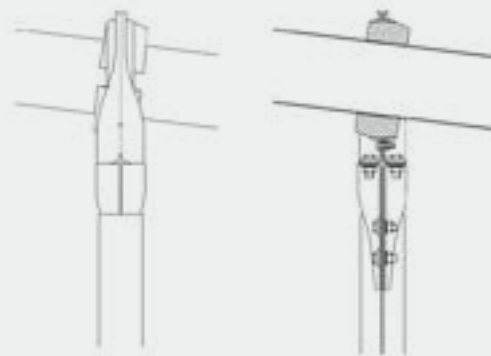
**Image 19:** Slope tolerance west-east



**Image 20:** Slope tolerance west-east

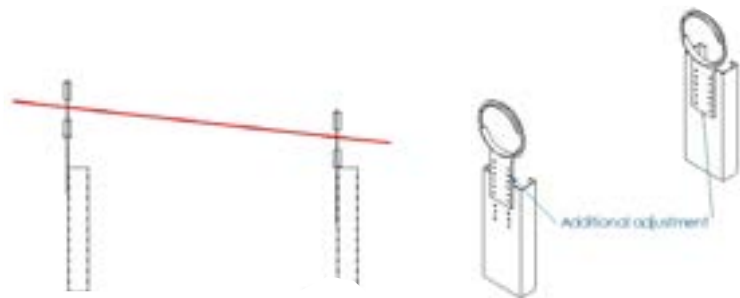


**Image 21:** TrinaTracker spherical bearing installed in N-S slope



**Image 22:** TrinaTracker spherical bearing performance when installed in N-S slope

Since the cylindrical bearings are typically larger, heavier, more difficult to mount, and require more substantive housings, they become disadvantageous when achieving perfect alignment.



**Image 23:** Cylindrical bearing performance when installed in N-S slope

### 3 Prevention of the balls exit from the bearing housing (cavity) due to deviations or longitudinal torque loads.

The spherical geometry of the housing interface with the other spherical elements (the balls) prevents the latter from coming out of the bearing from disassembling itself during the operation.



Image 24: Front view of spherical bearing cut in half

### 4 Resistance of the assembly to axial loads

This happens due to the same reason mentioned in the previous point.

### 5 The self-adjusting nature of the spheric geometry

Being **self-adjusting** eases the assembly process of the tracker.



Image 25: Spherical bearing installed in Vanguard 2P

### 6 The 50% reduction of assembly time and cost

The **spherical bearing** allows a reduction of at least **50% of the assembly time** of each post, resulting in a considerable reduction of the overall installation time.

Approximate data for assemblies		
Tracker Vanguard	Spherical	Cilindrical
N° of bearings per tracker	13	13
Time per bearing (h)	0.43	0.86
Total time extra bearing (h)	0	5.59
Time per tracker (h)	31.75	37.34
Time increase		15%
Time per MW	412.75	485.42
Saving Time per MW (h)		72.67
Total days in saving		9.08

Table 3: Reduction of assembly time

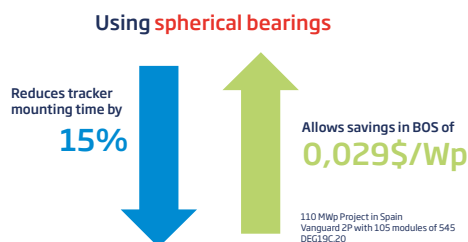


Image 26: Time and cost savings

Besides time reduction, **spherical bearings** also contribute to a lower LCOE. For example, when assembling **spherical bearings** instead of cylindrical bearings in a standard **TrinaTracker Vanguard 2P** tracker, the BOS cost is reduced by 0.029 \$ per Wp and assembly times decrease by 15 %.





5

# Materials

The right selection of the plastic material on the bearing is critical. It influences the level of interactions, friction, and resistance to the loads to which it will be subjected.

**TrinaTracker** uses different bearings according to the torque tube sizes. There are two material combinations between housing and moving parts:

1. Plastic-Plastic
2. Plastic-Metal

The use of plastic material in the sphere **avoids the need for lubrication** in the bearing and eliminates its maintenance.

The combination of plastic material and the spherical shape of the bearing give the set good **anti-sand and anti-ageing properties**.

The sphere's design has been carefully developed to achieve optimization of the geometry and the maximum use of plastics injection.

## 1 Plastic Materials

The plastic parts of the bearing are:

1. Spheres or moving parts
2. Housing, in the case of 100 and 120 bearings

The used materials are the following:

1. Spheres: POM
  1. Good mechanical properties
  2. Minimum friction to provide reasonable slippage
2. Housing: PA6.6 GF30
  1. Good mechanical properties
  2. Good UV resistance
  3. Good outdoor resistance

The choice of these materials has been the result of the **analysis, testing, and evaluation** of different mixtures of the materials mentioned above and other plastic injection options.

UV resistance: the materials used are highly resistant to radiation from the sun, and therefore have a high resistance to ageing outdoors. They also stop the sand and dust getting inside the bearings they are anti-abrasion and have a high level of hardness.

All materials are **certified** by our plastic parts supplier.

## 2 Metallic Materials

**TrinaTracker** uses two types of metallic materials:

1. S 355 MC + galvanized
2. Magnelis S 420GD ZM310

The design of each of these materials was successfully **tested** for traction, compression, lateral and axial load behaviour.



**Image 27:** Plastic part of bearing component

# 6

## Testing and Verification

# 6 Testing and Verification

Each type of bearing is configured to withstand the maximum loads for which the tracker is designed.

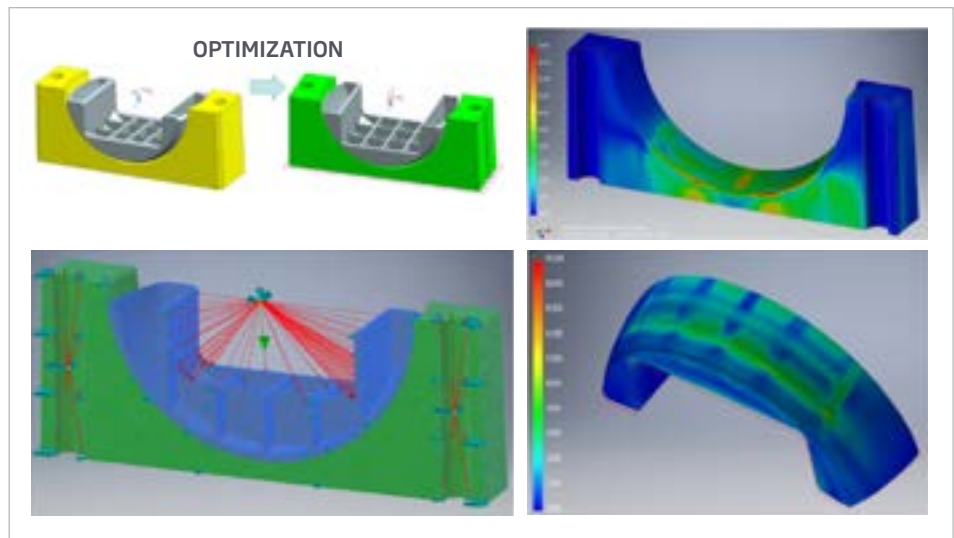
The **maximum allowable** loads for bearings are evaluated and defined for subsequent projects by the R&D team.

The geometry of the bearings allows high resistance to radial loads (vertical and horizontal) and axial loads due to the ball's spherical shape.

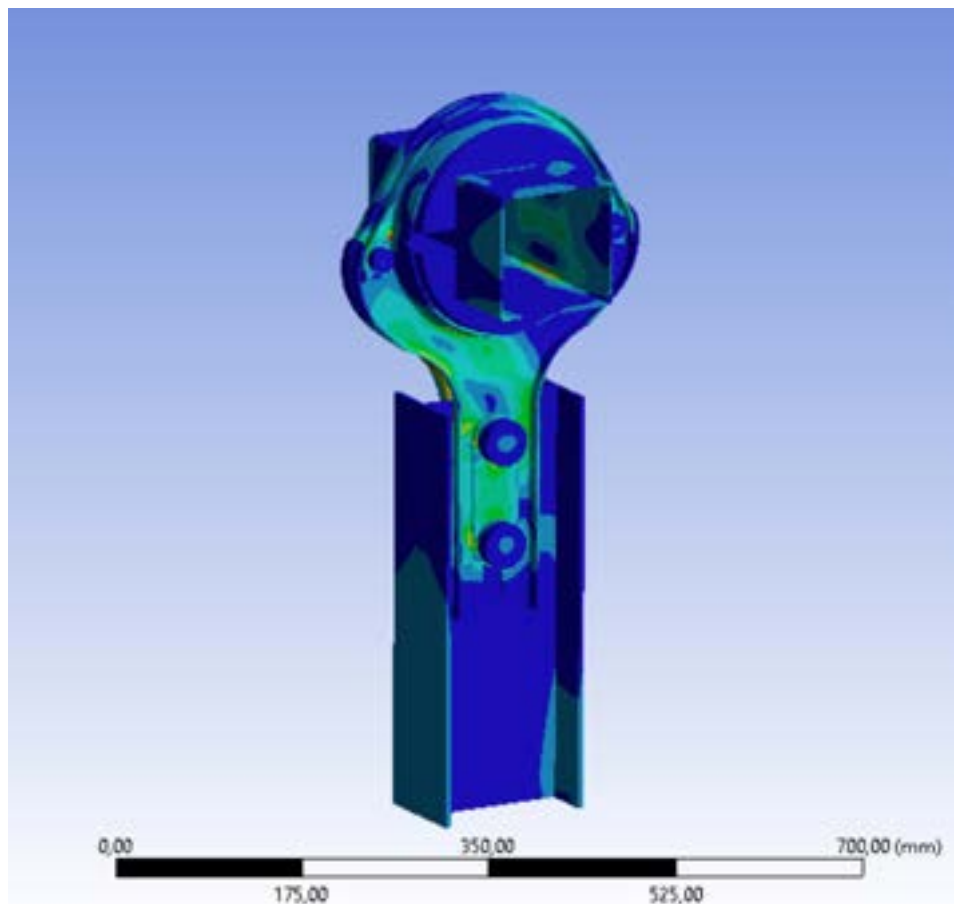


**Video 3:** Operation of **spherical bearing**

**FEM studies** are carried out on each model using the resulting loads to evaluate their structural adequacy under ultimate loads and optimize and check the geometry according to the plastic properties in the injection of the material.



**Image 28:** Optimizing calculation of plastic part of bearing component



**Image 29:** FEM calculation sample

Load tests are performed at in-house **TrinaTracker** facilities or **specialized testing laboratories** to evaluate the maximum mechanical load to which the bearings can be subjected to.



Image 30: Spherical bearing testing



Image 31: Spherical bearing testing



Image 32: Spherical bearing testing



Image 33: Spherical bearing testing

The tests are carried out following the EN1990: 2002. This regulation establishes a system of repetition of assessments to come at the resistance values of the union employing a statistical calculation.





**Minimal Failure Rates**

# 7 Minimal Failure Rates

**Spherical bearings** report hardly any failure rate during the whole operation phase of the plant. Therefore, the installation of this component contributes to a reduction of operation and maintenance costs and tasks, **lowering LCOE** providing **higher ROI** to **TrinaTracker's** clients.

The failure rates shown below are reported for **Agile 1P** and **Vanguard 2P\***.

Warranty	Component name	Units per Tracker (N°)	Units per 100 MWp (N°)	Replacement Time per unit (min)	Replacement Time per unit (hr)	Failure Rate per compon. (%)	Unplanned O&M Time (hr/year)
5 years	Bearing	16.0	25.520	15	0.25	0.0250%	1.60

**Table 4:** Spherical bearing failure rate in Agile 1P

Warranty	Component name	Units per Tracker (N°)	Units per 100 MWp (N°)	Replacement Time per unit (min)	Replacement Time per unit (hr)	Failure Rate per compon. (%)	Unplanned O&M Time (hr/year)
5 years	Bearing	8.2	13.317	120	2.00	0.0250%	6.66

**Table 5:** Spherical bearing failure rate in Vanguard 2P

\* Data gathered from **TrinaTracker** data base



8

## Spherical Bearing Performance

# 8

## Spherical Bearing Performance

### Zuera 11 MW: Spherical bearings' excellent and long-lasting performance

Zuera is an 11MW PV plant installed in Zaragoza, Spain. Since its interconnection in 2008, no failure ratio has been reported, therefore the installation has become an example of spherical bearings' excellent and long-lasting performance.

It was in **Zuera** where the first **spherical bearings** were assembled in trackers, and nearly **one and a half decades** have passed with no instances of suboptimal actuation.



Image 34: Spherical bearings installed in Zuera 11 MW, Zaragoza



Image 35: Zuera 11 MW, Zaragoza



## Tongchuan, 30 MW: Spherical bearings' efficiency in uneven terrain

**Tongchuan** is a 250 MW plant installed in China. The project is divided into two parts: 30 MW with TrinaPro and 220MW with fixed tilt racking system.

Surrounding mountains decreased site accessibility to both construction crews and materials. The **undulated terrain** added one more challenge to the plant design and installation.

**TrinaTracker** employed adjustable bearing supporting structure along with flexible **spherical bearing** and reduced number of piles per tracker to alleviate construction complexity in this project, expediting the installation process.

**Tongchuan** project, which trackers have all spherical bearings assembled, achieve 3.5% better LCOE, brings 7.75% more generation output and 0.6% better IRR than fixed tilt structure. The results reinforce our confidence in our products and services for our customers worldwide.



Image 36: Tongchuan 250 MW, China

# Conclusions




# Conclusions

**TrinaTracker** has always focused on **lowering risk and LCOE**, aiming its resources to continuously reduce product failure and achieve the highest and most assure long term energy outcome for our clients.

This is achieved by **TrinaTracker's Research and Development Department** fanatical continually improvement of every element in the design of the company's trackers, both at component level and as holistic system upgrading every single one of its components, increasing the solar systems' reliability and decreasing failure rates precipitously.

This document aims to demonstrate the advantages of employing **spherical bearings** in place of cylindrical bearings by evaluating all possible load conditions in service. The benefits have been shown from different analyses and comparisons.

Some of the main advantages summarized in this document are:

 <p><b>TrinaTracker</b> patented <b>Spherical Bearing</b></p>	▶ <b>Elimination of the twist of the post and the fails on the driving</b>	▶ <b>Reduction of installation time</b>
	▶ <b>Absorption of the slopes of the ground</b>	▶ <b>Easing assembly time and facilitating assembly</b>
▶ <b>Improved regulation on all tracker axes</b>	▶ <b>Reduction in civil cutting and terrain preparation costs</b>	▶ <b>Decrease in costs arising from assembly rework</b>
▶ <b>Self-alignment</b>		▶ <b>Lack of bearing maintenance or adjustment during the lifetime of the PV plant</b>

As explained here, the bearing is one of the essential parts of the tracker, and **TrinaTracker** patented **spherical bearing** is recognized worldwide as industry leading.

Hundreds of customers and our own experience confirm these benefits.



Images 37, 38 & 39: **Spherical bearing** assembling example



10

## Competitive Advantages of TrinaTracker

# Competitive Advantages of TrinaTracker

**TrinaTracker**, a business unit of **Trina Solar Ltd.** (SHA:688599), is a global solar tracker technology leader focused on providing “state-of-the-art” design solutions tailor-made to any terrain characteristics and weather conditions.

The company has more than 6GW of solar trackers deployed in 40 countries in which they accurately adapt the solar systems to each site’s features. **TrinaTracker Agile 1P** and **Vanguard 2P** stand out in the market for their reliability, optimized design and minimal operation and maintenance requirements.

The trackers’ compatibility with ultra-high power modules has been reported by **DNV**. Furthermore, **Agile 1P** and **Vanguard 2P** have been subjected to static, dynamic and aeroelastic loads through the most extensive tunnel test implemented in the solar industry and performed by leading wind engineering consultants, **CPP** and **RWDI**.

**TrinaTracker** is entirely focused on quality and innovation to provide its clients with high-technology solutions that achieve the highest energy yield and lowest **BOC** costs and **LCOE**.

## About Trina Solar

Founded in 1997, **Trina Solar** is the world-leading PV and smart energy total solution provider. The company engages in PV products R&D, manufacture and sales; PV projects development, EPC, O&M; smart micro-grid and multi-energy complementary systems development and sales; and energy cloud-platform operation.

In 2018, **Trina Solar** launched the Energy IoT brand, established the Trina Energy IoT Industrial Development Alliance and leading enterprises and research institutes in China and around the world and founded the New Energy IoT Industrial Innovation Center. With these actions, **Trina Solar** is committed to working with its partners to build the energy IoT ecosystem and develop an innovation platform to explore New Energy IoT, as it strives to be a leader in global intelligent energy. In June 2020, **Trina Solar** was listed on the STAR Market of the Shanghai Stock Exchange.

For more information, please visit [www.trinasolar.com](http://www.trinasolar.com).

# TrinaTracker

## Competitive Factors

**Own** R&D & Engineering Department



**Team** of more than **50** experienced and highly qualified engineers



**Consolidated expertise** in modelling, calculation and engineering design



**Extensive know-how** of solar industry technology and markets



**+6 GW** of plants where tracker design is tailor-made to meet the site characteristics and clients' requirements



Trackers installed in more than **40 countries**



**In-house resources** to carry out geotechnical design, structural design, FEM analysis, physical testing, software and hardware design, detailed project design, research and development of products.



**Work partnership** with leading wind engineering consultancy companies (**RWDI** and **CPP**)



State-of-the-Art **engineering design**



Designed technology that complies with the highest **European and US standards** (IEC62817 and UL3703 Certifications respectively)



WIND ENGINEERING & AIR QUALITY CONSULTANTS





# 11

## State-of-the- Art Engineering Solutions



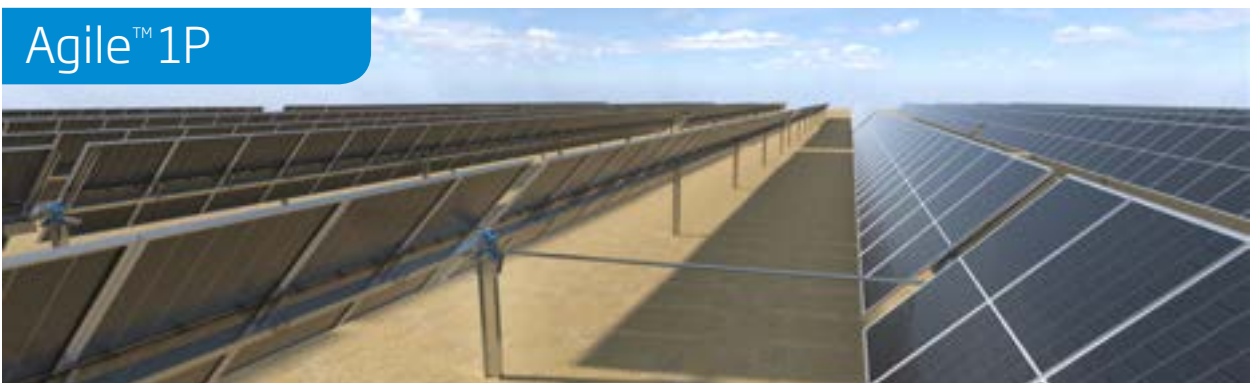
# State-of-the-Art Engineering Solutions

## Vanguard™ 2P



- 2P configuration compatible with ultra-high power modules up to 210 mm wafer size.
- Multi-drive system that allows better wind tolerance, high adaptability and stability.
- 120 modules per tracker and up to 4 strings per row. Low voltage optimisation.
- Individual row actuator. Easy access for operation and maintenance activities.
- From 7 piles per row and less than 120 piles per MW.
- Global patented **Spherical Bearing** that allows up to 30% angle adaptability.
- **SuperTrack** algorithm that increases yield gain up to 8%.

## Agile™ 1P



- Individual row actuator. Easy access for operation and maintenance activities.
- 120 modules per tracker and up to 4 strings per row. Low voltage optimisation.
- Dual row actuator. Easy access for operation and maintenance activities.
- Optimised number of components allows low operation and maintenance costs.
- High slope tolerance 20% N/S, 10% E/W.
- **Trina Clamp** reduces installation time and costs.
- **SuperTrack** algorithm that increases yield gain up to 8%.



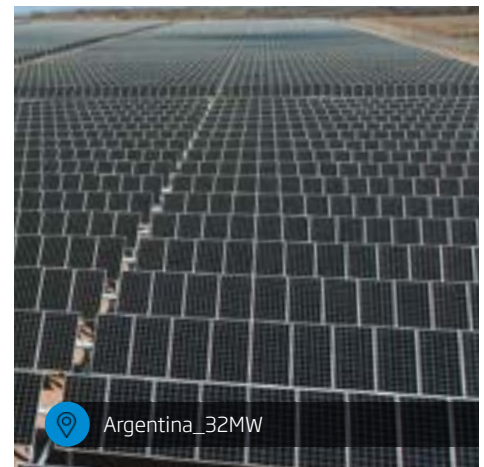
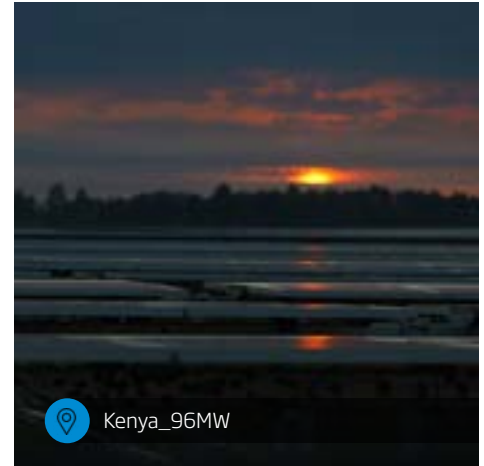


12

**+6 GW of Global  
Installations**

12

# +6 GW of Global Installations



The logo for TrinaTracker, featuring the word "Trina" in blue and "Tracker" in red, with a small red dot above the 'i' in "Trina".

TrinaTracker

[www.trinasolar.com](http://www.trinasolar.com)

The logo for Trina solar, featuring the word "Trina" in blue and "solar" in a lighter blue, with a small red dot above the 'i' in "Trina".

Trina solar